

WLM.1900 Wall Mount Valve

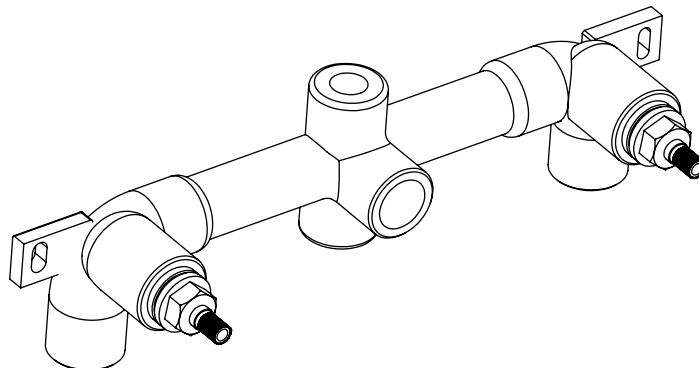

NOTICE TO HOMEOWNER

- We recommend that this product is installed by a qualified professional plumber.
- Please check this product immediately to ensure that it has not been damaged and is complete. Before installation, please make sure this product is the correct model and you have all the parts required for installation and use.
- Please flush the water system to ensure that no metal swarf, solder, and other impurities can enter the product.
- Turn off water supply before commencing work.
- Please read these instructions carefully and retain for future reference.

BEFORE YOU BEGIN

- You must observe all local plumbing laws and codes.
- Do not install this valve if it does not meet local plumbing codes.
- Shut off the main water supply.

WLM.1900 Wall Mount Valve

TABLE OF CONTENTS

• Operating Specifications	1
• Valve Installation And Tolerance	2
• Connecting Supply Lines	3
• Installing The Product	4

OPERATING SPECIFICATIONS

WATER TEMPERATURE



This product is to be used with water at a temperature range of 40°F - 120°F ONLY!

WATER PRESSURE



This product is to be used with a water pressure range of 15 PSI to 80 PSI ONLY

If water pressure is greater than 80 PSI install a pressure reducing valve (PRV)

This valve meets or exceeds ANSI A112.18.1 and ASSE 1016

VALVE INSTALLATION AND TOLERANCE

CUT-OUT DIMENSIONS

Isenberg's wall mount two handle lavatory valves does not come with a mud guard.

It is essential to review the cut-out dimensions shown on the left in dotted circular lines so that the proper hole sizes are cut-out in the finished tile.

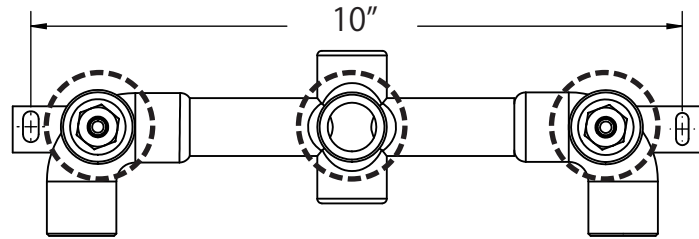

3x \varnothing 1.3" [33mm]

VALVE INSTALLATION INTO THE WALL

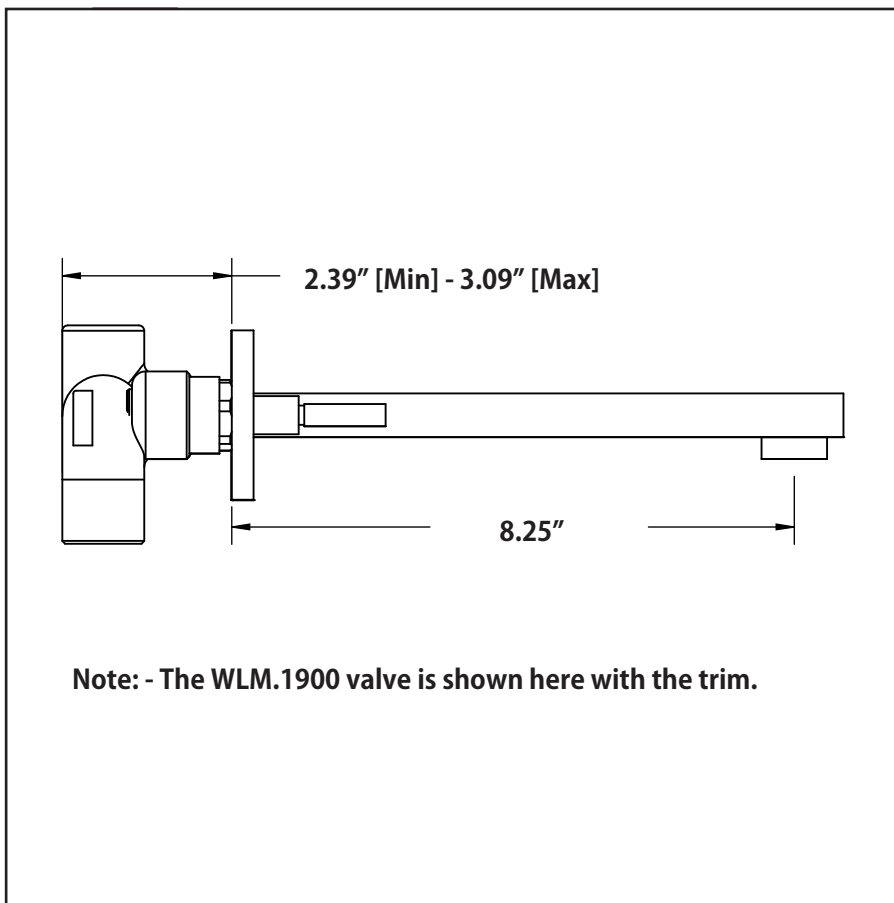

Install a crossbeam at the location where the valve will be installed. The distance between back of the valve to the finished tile surface should be between 2.39" and 3.09".

Level and mount the valve to the crossbeam. Ensure valve is straight and do not install at an angle or upside down.

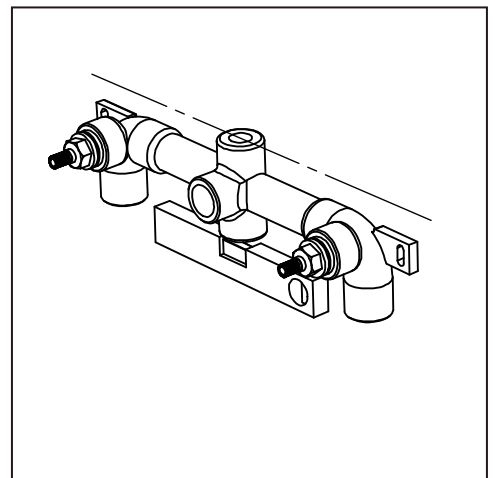

CONNECTING SUPPLY LINES

Connect valve to the hot and cold supplies using 1/2"-NPT copper supply lines. Do not apply heat directly to the valve as this may damage rubber and plastic seals and will void the warranty.

TESTING THE VALVE

Prior to completing the finished wall, fully test valve function to ensure that valve is working properly (see FLUSHING & PRESSURE TESTING section below).

Ensure that no leaks are present. Check cartridge function. To test valve function turn on the water to make sure both hot and cold supplies are working.

FLUSHING & PRESSURE TESTING

1. BEFORE INSTALLATION OF DRY WALL AND CLOSING OF WALL OPENINGS

The system must be flushed and pressure tested. Metal chips and sand commonly found in plumbing pipes can damage the components of the valve.

2. Ensure that both hot and cold supply lines are turned off. Ensure that the cartridge stem is in the off position. Remove the cartridge and slowly turn on the hot and cold supply lines. This will flush out the valve body and pipes.

INSTALLING THE PRODUCT

